

CUSTOMER TERMINAL	ROHS	Lead(Pb)-free
	Yes	Yes

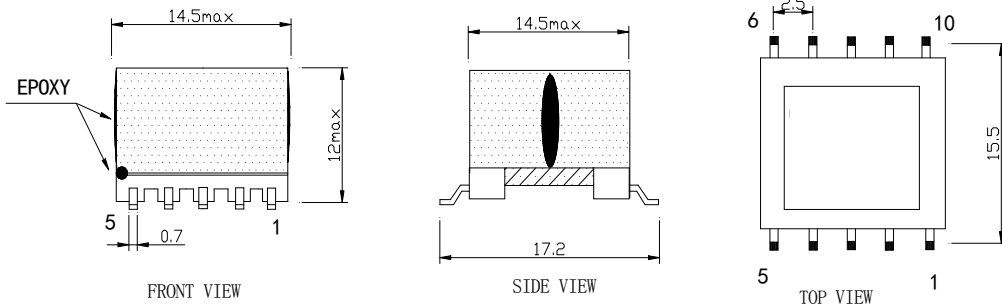

### 1. Mechanical Dimensions: (mm)



### 2. Schematic Diagram

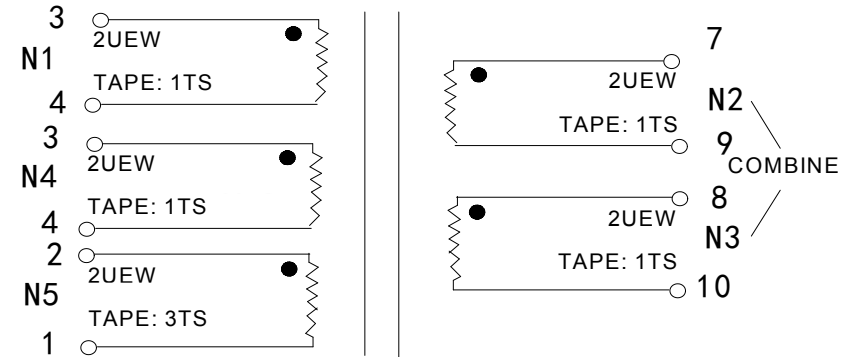

NOTE: **DOT ABOVE PIN 1.**

### 3. Material List

Core: FW4-EP13  
 Bobbin: SFWB1301 5+5PIN  
 Wire: 2UEW-F  
 Tape: 8mm/w(white)  
 Epoxy: E-500

### 4. Electrical Specification

Inductance:  $L(3-4): 127\mu H \pm 10\%$ , (1KHZ 1V)  
 DC Resistance:  $R(3-4) = 0.5\Omega$  Max.  
 Dielectric Strength: Between P-S No Break-down Applied AC 1500V/1mA/60S  
 Dielectric Strength: Between coil-core No Break-down Applied 1000V/1mA/60S

REV.	DATE	<p>Convention placement</p>	DRW.	DRAWING TITLE	Part No:		
0	03/15		CHK.			<b>TRANSFORMER</b>	FWPTPE13SMD130K-2
			APP.				
		www.ferriwo.com			SPECIFICATION SHEET 1 OF 1		

THIS DOCUMENT IS STRICTLY NOT ALLOWED TO BE DUPLICATED WITHOUT AUTHORIZATION